

*innovative spare parts*



# KILN BOOK

2021

  
MADE IN ITALY



# CONTENTS

- 4 Ceramic Rollers
- 5 Special Rollers
- 6 Supporting Slabs/ Food Plates
- 7 Supporting Slabs for roller kiln
- 8 Oxide Calcining Saggars
- 9 Crucibles
- 10 Cordierite Chicanes
- 11 Burner Cones and Diffusers
- 12 Sacmi Kiln Vault
- 13 Siti Kiln Vault
- 14 ModulaRS
- 15 Roller Passages
- 16 SiC Bars/ Bottom Batts
- 19 Intermediate Batts/ Thermocouples
- 20 Ceraboard
- 21 Insulating Blocks
- 22 Insulating Bricks
- 23 Pulling Equipment
- 24 Various products
- 25 Artistic Sector
- 26 Standard and ecological fibers
- 27 Fiber and Ecological Mattresses
- 28 Various/Photos





## GROWTH AND EXPERIENCE

1973. Roteglia, Castellarano (RE), Italy.

At the heart of the ceramic district, Refrattari Speciali was founded.

The company began its activity manufacturing supports made of Cordierite for the ceramic, bathroom furnishing and tableware industries. Today Refrattari Speciali is a reference point worldwide when it comes to the production of ceramic rollers and Cordierite products.

Experience and perseverance lie behind the over 45 years of activity of the company. They are today's treasure, by means of which, the company, with its unchanging company philosophy, offers its customers top quality products.

The first step was the production of sliding slabs and saggars for single-firing; the company then engaged in the production of any type of refractory support for use in kilns. Ceramic rollers are the nerve centre of the production program.

These are products that resist time and wear and that are capable of providing added advantages in terms of quality and innovation. Commitment towards innovation has also allowed the company to expand into new sectors of research and development. A cutting-edge laboratory has made it possible to offer a new patented product to the market: ModulaRS, an innovative and versatile refractory element which allows use in many applications.

**Sturdiness, Resistance and Innovation.**

The three milestones on which over 45 years of work have been founded.

## THE PROFESSIONAL APPROACH

**Refrattari Speciali** means quality and safety.

The UNI EN ISO 9001:2000 (ISO 9001:2000) certification obtained in 1996 guarantees efficiency and high production standards.

A highly qualified staff, composed of the Technical Director, the Quality Manager and engineers, constantly ensures that production meets the certified level of excellence.

Refrattari Speciali operators work to obtain the best performance in a work environment that is both safe and compliant with standards.

## AT THE HEART OF QUALITY

The achievements of Refrattari Speciali are the result of the following essential factors: quality, versatility, innovation, customer satisfaction and just-in-time service.

The customer and its needs. These are the priorities.

The wisdom of tradition and the freshness of innovation. Efficient, qualified and hardworking technicians, ready to offer a large range of solutions for any necessity.

**THE COSMOPOLITAN APPROACH** Refrattari Speciali is an international reference point. Local agents are present in the most important markets to optimize the development of the company and provide timely assistance to customers irrespective of where they are. The reference points of the company are the warehouses located in various important areas so as to fulfil the needs of the market.

Throughout over 40 years of activity, the company has had the chance to experience different economic situations, societies and cultures. Refrattari Speciali has worked with large-scale and emerging companies, established and small-scale companies and has therefore learnt how to adapt to any situation.









# Ceramic Rollers

Our thirty years of experience in the production of ceramic rollers and constant research and experimentation, carried out with the collaboration of the main world users, allows us to offer a complete range of qualities for all uses.

CHEMICAL-PHYSICAL PROPERTIES		K400	K400R	K600	K2000	K2000HL	K1	K-SILK	CARSIAL	KZ
Alumina content Tenore in allumina	$Al_2O_3 + ZrO_2$	74-75%	75-76%	80-82%	81-83%	81-83%	81-83%	72-75%	-	80-82%
Bulk density Peso volumetrico	g/cm <sup>3</sup>	2,3-2,4	2,65-2,75	2,7-2,8	2,8-2,95	> 2,98	2,98-2,99	2,4-2,6	2,35-2,45	2,7-2,8
Water absorption Assorbimento Acqua		10,5-12,5%	7,75-8,25%	6,5-7,5%	4,5-6%	3,8-4%	3,8-4%	<0,5%	-	6,5-7,5%
Modulus of rupture Resistenza flessione a freddo	N/mm <sup>2</sup>	>37	43 ± 4	44 ± 6	44 ± 5	54 ± 5	59 ± 5	>50	-	44 ± 6
Thermal expansion at 1000°C Dilatazione termica a 1000°C	E <sup>1</sup> /K	5,4-5,8	6,1-6,4	6,1-6	5,8-6	5,8-5,9	5,6-5,8	5,5-5,6	4,4,20	6,1-6
Thermal shock resistance Resistenza allo sbalzo termico		Very Good	Very Good	Very Good	Very Good	Very Good	Very Good	Very Good	Very Good	Very Good
Max suggested working temperature Temperatura max di esercizio		1250°C	1270°C	1300°C	1350°C	1350°C	1350°C	<1000°C	-	1300°C

The technical data are obtained from laboratory tests on production control and they give no guarantee.

-  **K400** Standard quality ceramic roller. It can work at 1180°/1190°C in low chemical aggression conditions.
-  **K400R** Very good resistance to chemical aggression. Good resistance to flexure. Highly recommended for the production of technical porcelain stoneware.
-  **K600** It is the optimal evolution of K400R. It has a lower absorption than K400R. High resistance to flexure. It can work at a high speed whilst maintaining constantly high parameters. This makes it an ideal choice when the production capacity of the kiln is increased.
-  **K2000** It resists acid or basic pH, therefore it is particularly handy when it comes to clay with a high percentage of sodium or potassium and glaze containing aggressive frit. It is used for the production of glazed porcelain stoneware, neutral technical stoneware or with crystal surface finishes, thick products or when extra long rollers are needed.
-  **K2000HL** It has a greater resistance to flexure, when hot, compared to K2000, which makes it suitable for tiles with a thickness of 25/30 mm. It is manufactured using special raw materials and by eliminating any impure particle during production.
-  **K1** It's designed purely for thicked formats: it reaches stiffness and bending resistance levels never achieved before. Accurate raw materials selection, lower average grain size and higher firing temperatures allow to obtain deeper roller sintering: that permits to achieve a great increase of thermo-mechanical properties and a smoother roller surface. In this way the sediment on the roller surface can be limited, this let to reduce the frequency of maintenance, then the costs.

#### PRECAUTION FOR USE:

**STORAGE:** keep the ceramic rollers in dry places, don't expose them to bad weather. Lay the boxes on flat surfaces to avoid distortion to the material.

**INSERTION IN THE KILN:** dry the ceramic roller evenly before insertion in kiln (preferably in dryer zone), in order to eliminate residual moisture as much as possible.

Insert the ceramic roller in the kiln as quickly as possible and rotate it at the same speed as the pulling.

During working the ceramic roller must always be in rotation; if this were to stop, the heat of the kiln and the load would irreparably deform the product (hot bending).

**EXTRACTION FROM THE KILN:** the correct operation requires a slow temperature drop down to 1000 ° -1050 ° C, then the ceramic roller can be extracted.

The result (if the roller has not undergone particular chemical aggressions) will save a considerable percentage of them.

This operation becomes indispensable when working with thick ceramic rollers. The thermal behavior of these involves a much slower operation of lowering the temperature at about 900-950 °C.

- check that the temperature of the roller allows it to grip
- check that there are no slag or sharp parts on the roller
- help yourself by using hooks covered with insulating material
- lay the hot ceramic roller on appropriate supports and keep it rotating during cooling
- absolutely avoid contact of the hot roller with cold material (metal, floor, etc.)
- remove the still usable mechanization components from the old roller





### RULLO BLOWER UP

Blower Up roller for cooling zones. It's available in Silicum Carbide or AISI 310.

## SPECIAL Rollers

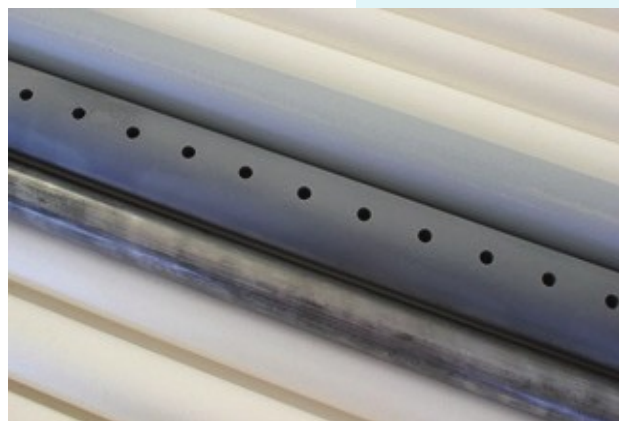

### KZ TOOTHED ROLLER

toothed roller for rapid cooling zone. It allows passage of air between the roller and the product in the cooling zone. In this way, it is possible to avoid the longitudinal undulating effect on the roller hence reducing the so-called "jumping" effect on the tile.



### K-SILK ROLLER

Smooth and soft surface equal to the silk. Roller with very low absorption and high bending resistance. Developed for preheating zone of the kiln, it doesn't suffer chemical attacks. K-SILK is a performance Roller and helps the hard production process, especially in the kiln with large mouth. K-SILK finds its best expression of work between 200°C and 800°C.



### CARSIAL ROLLER

It's indicated for first rapid cooling zone. In this way it's possible to eliminate the longitudinal wave effect on the roller, decreasing the "jumping" effect on the tiles.



# SUPPORTING SLABS

Our supporting slabs are made of CORDIERITE/MULLITE and can be used until 1300°C. They are used in many different ceramic fields because of the high resistance and the very low coefficient of expansion. They are available in a wide selection of formats.

We have a high range of sizes, and further sizes can be realized on request.

EXAMPLE OF SOME FORMAT



A x B(mm)	sp(mm)
400x400	15-40
450x450	15-40
490x490	15-40
520x520	15-40
600x500	15-40
720x600	15-40

PERFORATED SUPPORTING SLAB	
450x450	14-40
490x490	14-40

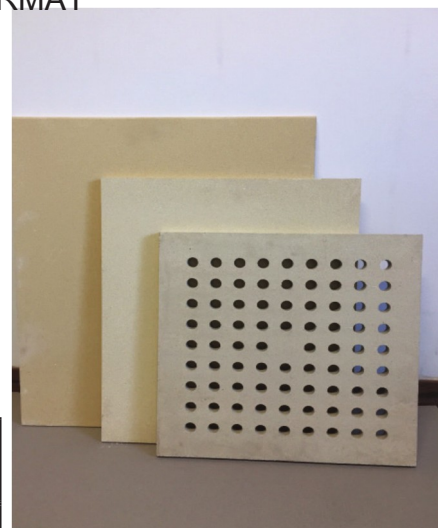

# FOOD PLATES

It's our classic cordierite, used for the realization of a whole series of plates suitable for the food sector. All our plates can be certified for cooking food use.

Ø(mm)	th(mm)
250	10-15
310	10-15
350	10-15
380	10-15



dimension example

AxB (mm)	th(mm)
450x340	15



# SUPPORTING SLABS FOR ROLLER KILN

The firing system in roller kilns for ceramic products such as mosaic, tableware and special pieces is a valuable ally in the Special Refractory plates.

The material and geometry are carefully designed to obtain resistant and light plates.

The excellent mechanical strength allows the safe handling with any type of automation; the low coefficient of expansion causes the plates are suitable for extremely rapid cycles; geometries are characterized by thin thicknesses (max 12 mm), holes and ribs that reduce the mass to be heated and the point of contact between the support and the workpiece in firing, with considerable energy savings.

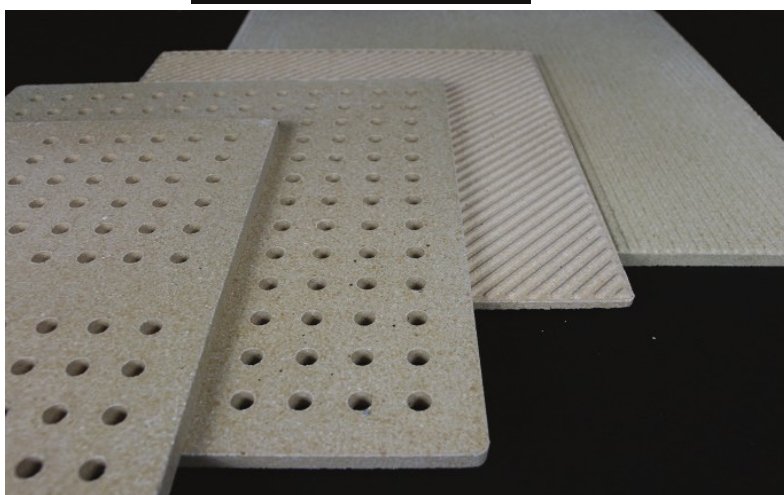
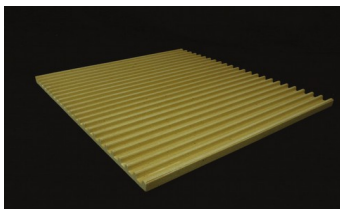
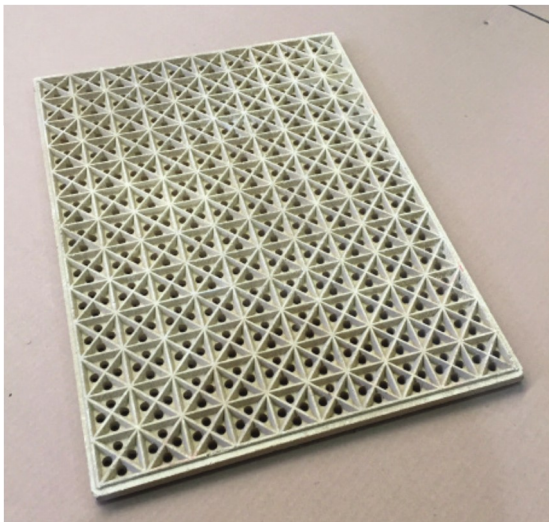
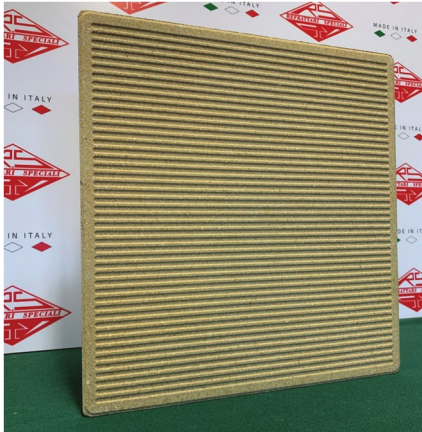

Formato	AxB (mm)	Sp(mm)
holed slab	340x340	11
smooth slab	350x350	10-15
holed slab	450x450	15
holed Poppi slab	480x360	15
holed shaped slab	400x380	12
holed shaped slab	520x360	12
holed shaped slab	560x460	12
2 sides striped slab	330x220	9
1 side/ 2 sides striped slab	340x340	9
2 sides striped slab	457x457	12,7
1 side striped slab	457x457	11-14
1 side striped slab	490x490	15

further formats and thicknesses can be realized on request

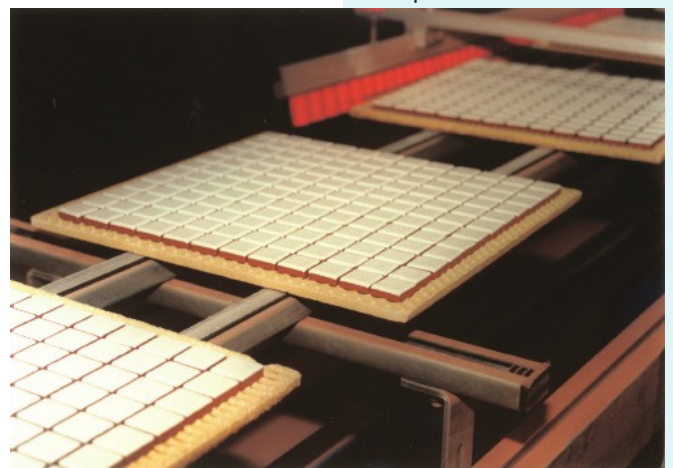

# OXIDE CALCINING SAGGARS

We can offer a wide range of formats, with or without holes, and with lid

	Quality	working temperature
STD	Cord.-Mull.	1300°C
HT	Mull.	1400°C



D(mm)	H(mm)	T(mm)
210	116	10-12
250	80	14
250	110	14
250	135	14
260	135	14-15
320	100	14-20
360	100	18-22

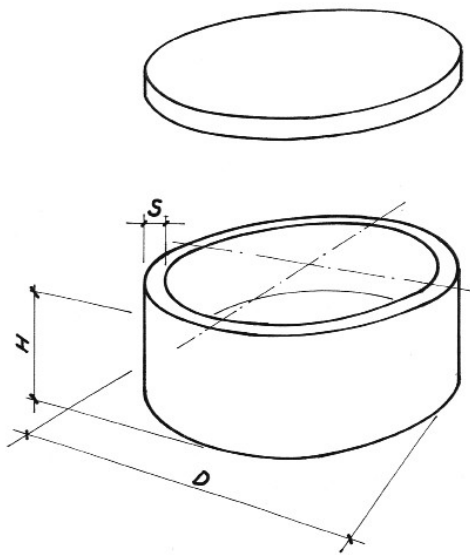

We monitor various production parameters to determine the final quality of the product, such as: water absorption, thermal shock resistance, constant weight of production lots, pressing of the wall and of the bottom, particle size analysis, etc. ...





# Crucibles

containers in refractory material resistant to high temperatures.

In particular, the prevailing mineralogical phase is mullite. The product can be used until a maximum temperature of 1500°C.

Ideal for tests on frits and for the production of small quantities, but they can also be used for melting or calcination of small quantities of material at the laboratory level.

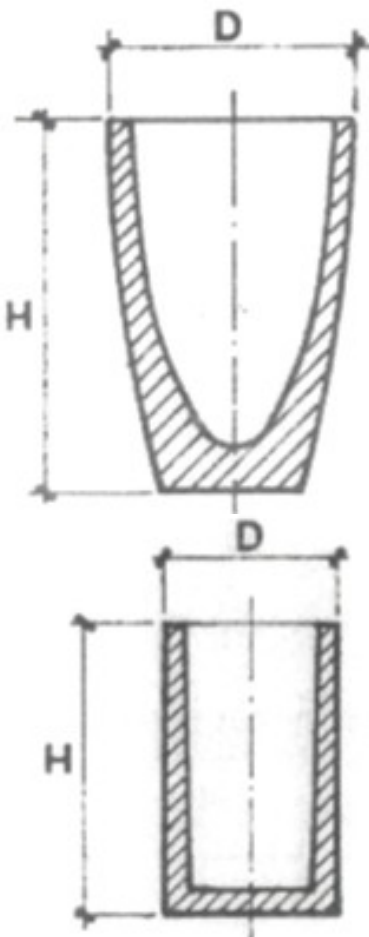

D(mm)	H(mm)	Capacity(L)
46	80	0,58

D(mm)	H(mm)	Capacity (L)
130	195	0,90
162	250	1,90
172	260	3,00

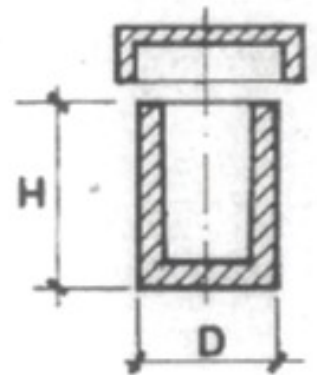

D(mm)	H(mm)	Capacity (L)
100	90	0,27
100	110	0,25
100	170	0,55
105	200	0,80



# Cordierite Chicanes

Chicanes are made of Cordierite Aluminous material. Material is characterized by a low thermal expansion coefficient and by a very good thermal shock resistance. This product is made through the extrusion process, which gives the piece high mechanical strength.



**APPLICATIONS:** chicanes are used as a vertical separator septum to create separate areas inside the kiln. This allows to uniform and maintain constant the temperature of the various kiln modules, consequently improving the quality of the products. Through the hole at the top chicanes are fixed to an anchor which in turn is hooked directly to the carpentry of the kiln.



**AVAILABILITY:** Chicanes are available in many formats according to the needs, and can also be realized some personalized sizes.

WIDTH (mm)	LENGTH (mm)	THICKNESS(mm)
120	885	12-13
	955	
150	885	
	955	
195	885	
	955	

## CHICANES FOR DOUBLE CHANNEL Kiln

In addition to cordierite chicanes, we can also offer you tilting mullite chicanes to equip your double channel kiln. A SiSiC bar is passed through the hole which acts as a sin anchor, and this in turn is fixed to the kiln carpet.

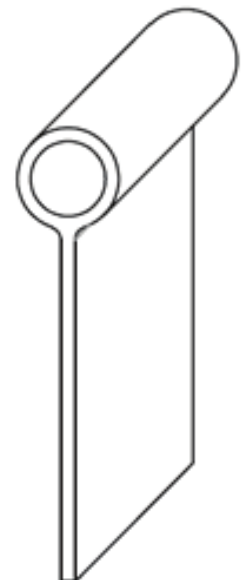

WIDHT (mm)	LENGTH	THICKN.
270,5	200	8
330,5		



# BURNER CONES AND DIFFUSERS

our burner cones and diffusers in **Silicon Carbide** are characterized by:

- very good thermal shock resistance
- greater resistance to usury and corrosion
- very good oxidation resistance
- easy installation
- longer service life compared to alumina burner cones
- maximum working temperatures

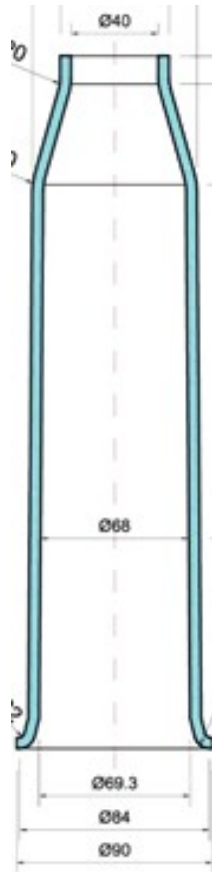

LENGTH (m)	Øin (mm)	Øout (mm)
210	130/70	36
310	130/70	43
320	90/69	40
320	100/68	50
375	98/70	40
375	100/80	40
375	98/70	60,7
395	90/70	40
410	130/70	37
450	100/68	50
487 4hole stop	98/70	stop
500 xRay 5hole	98/70	28
500	100/70	40

## DIFFUSERS

LENGTH (mm)	Øin (mm)
170	94/85
470	89/70
470 4 holes closed	100/70
470 4 holes open	100/70

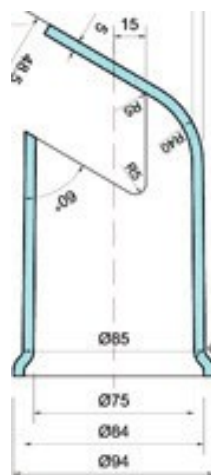

# SACMI KILN VAULT



## SUPPORTS

HEIGHT	DEPTH
385	120
310	120
225	120

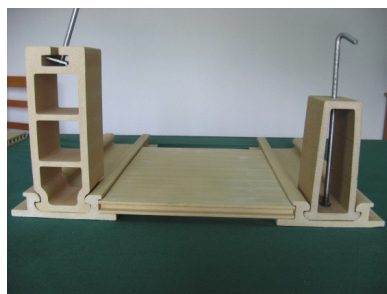
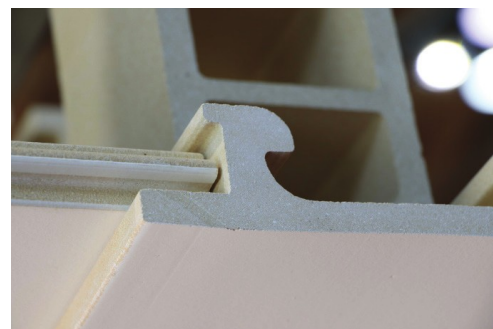

## SET-UP Exemple :

Supp. H=225 about 24 pcs/module  
 hanging rail L. 670 : about 12 pcs/module  
 batt 500x370x25 : about 20 pcs/module



## HANGING RAIL

WIDTH (mm)	LENGTH (mm)
210	on Request

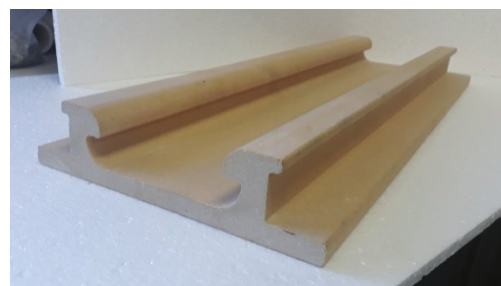

## BATTS

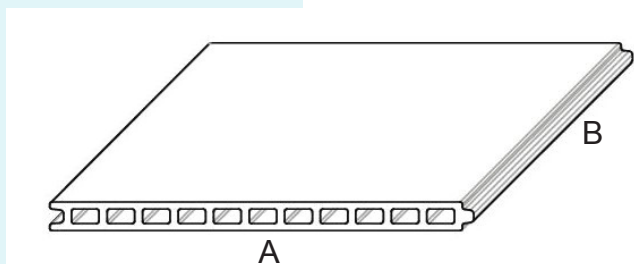

A (mm)	B (mm)	THICKNESS
360	370	25
	405	
	225	
410	370	
	405	
	225	
500	370	
	405	
	225	

We can carry out further sizes on request.

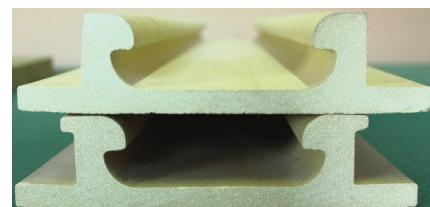

# SITI KILN VAULT

## SUPPORTS

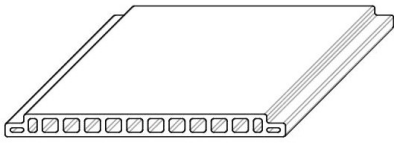

HEIGHT (mm)	DEPTH (mm)
160	110
225	120

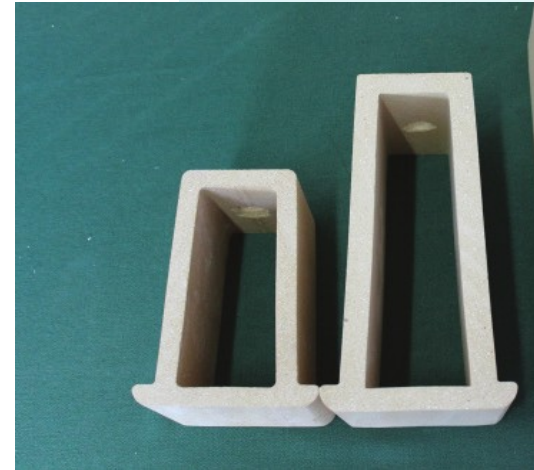

## HANGING RAIL

WIDTH	LENGTH
210	on request

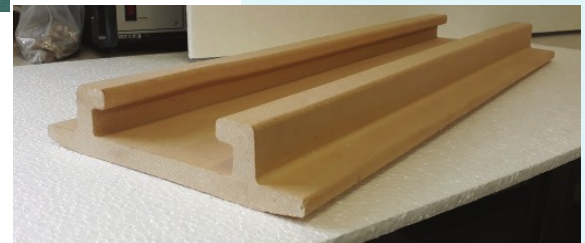
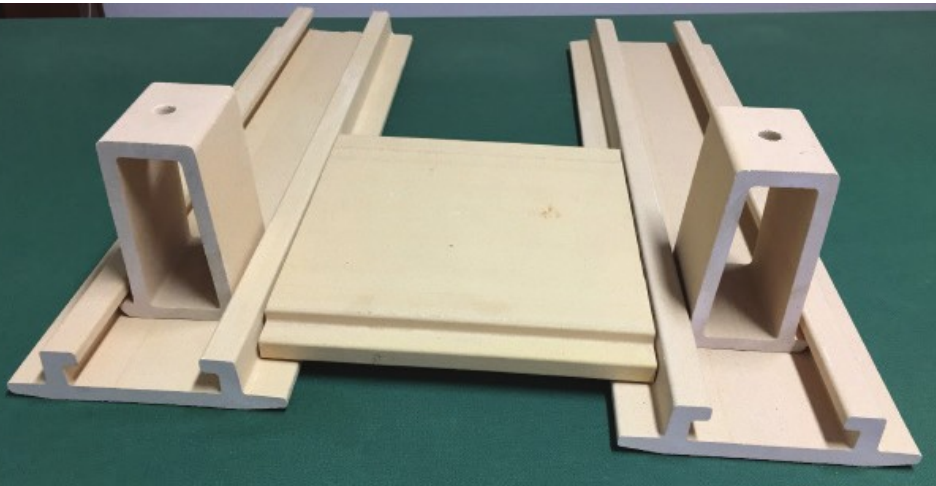

## BATTS

A (mm)	B (mm)	THICKNESS (mm)
371	305	30
	135	
396	305	
	135	
470	305	
	135	

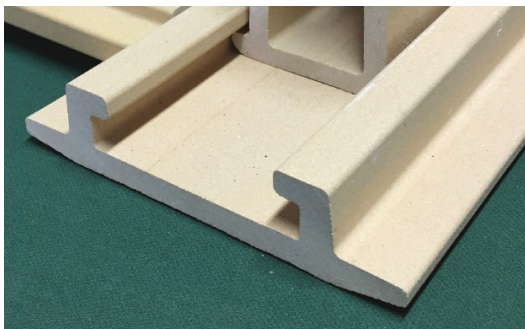
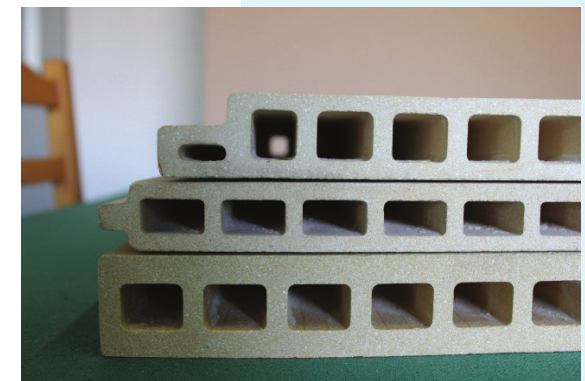

## JOINT

WIDTH	LENGTH	Thickness
48	on Request	11



# ModulaRS

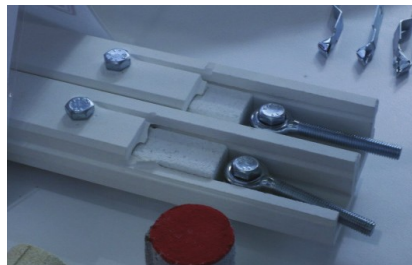
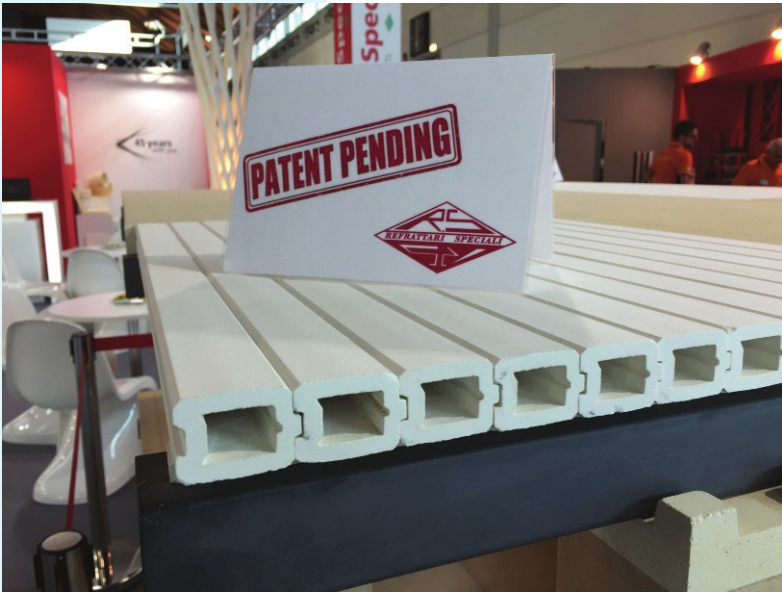
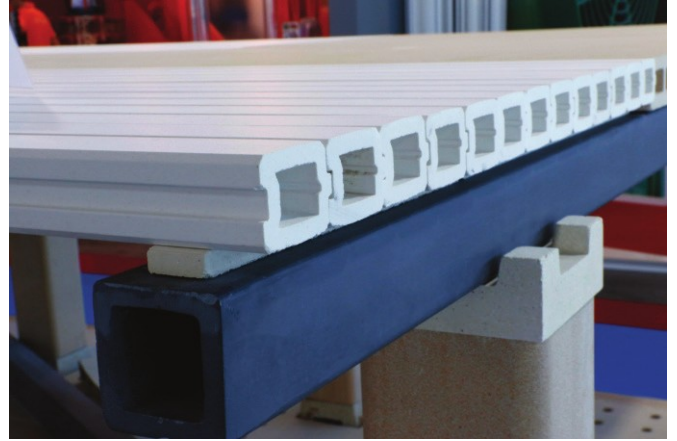



# ModulaRS

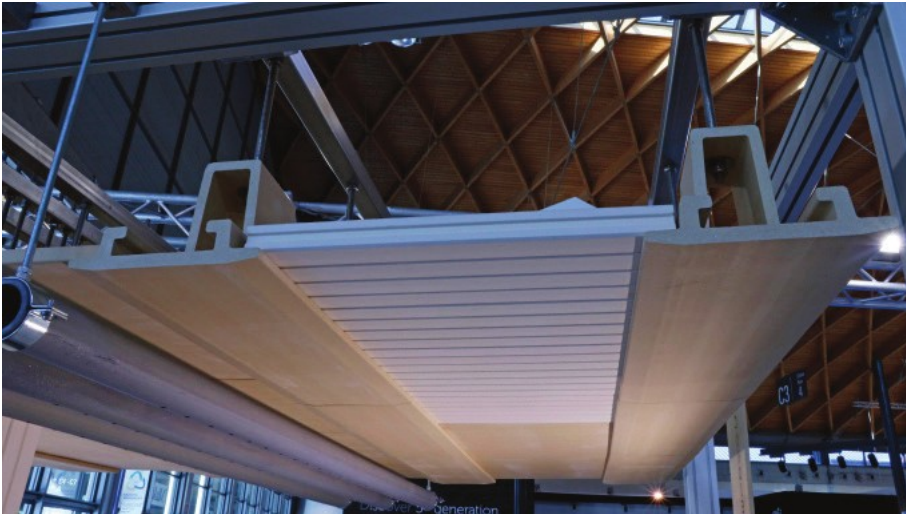
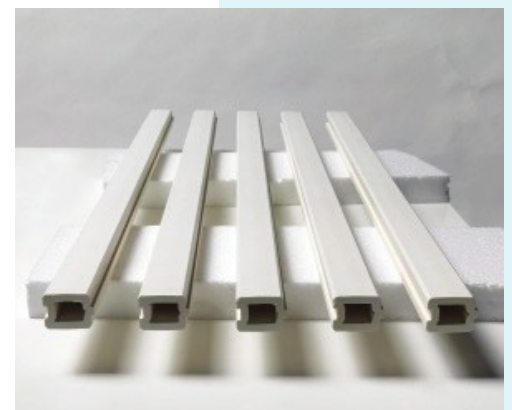

**MODULARS** is an innovative and versatile refractory element made with a high mechanical strength material, therefore can be obtained narrow and very long bars, up to 3000 mm.

Flanking the complementary elements between them, it forms a continuous surface without cracks between one element and the other. In this way we realize large ideal cooking plans, for example, for sanitary sector, where there are high loads.

High resistance to chemical attack results from the composition and low porosity. For this reason MODULARS is ideal as vault and walls lining in aggressive places

The particular geometry strikes the imagination:

**MODULARS** can remedy any need, especially in emergency case, with a simple cut .



# ROLLER PASSAGES

Our extruded roller passages can cover all the range of existing roller kilns on the market.

According to the specific needs of the kiln, we can offer two different qualities:

- **CORDIERITE** for maximum working temperature 1250°C
- **CORDIERITE/MULLITE** for maximum working temperature 1350°C

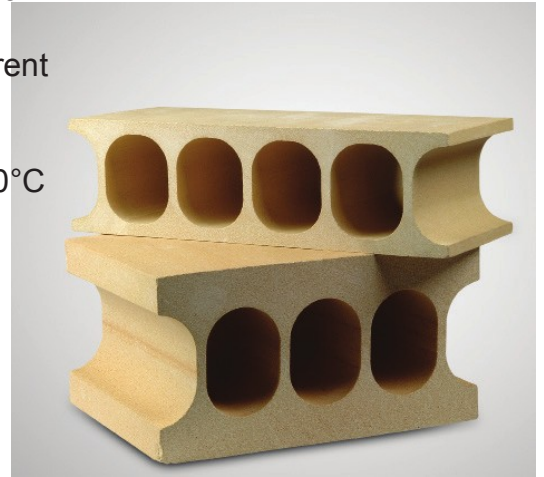
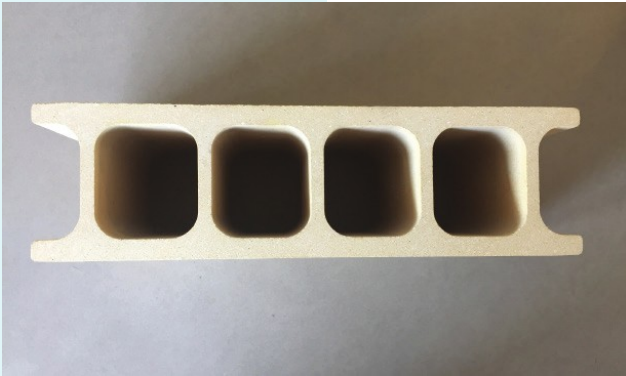

## SACMI DOUBLE CHANNEL ROLLER PASSAGE:

	PITCH	WIDTH (W)	HEIGHT (H)	DEPTH (P)
inf.double ch.	60	297	114	205/180
sup.doble ch.	60	297	114	205/180

## SACMI ROLLER PASSAGE

PITCH	WIDTH	HEIGHT	DEPTH
70	346	114	180
			145
			90
	205	114	180
			145
			90
171,5	114	180	
		145	
		90	
67,7	268	114	180
	236		
60	297	82	180
	238		180
			195
37	183	82	180

**AVAILABILITY:** We can offer a large range of roller passages with different pitches and lengths, characterized by thin thicknesses. Further formats can be realized on request.





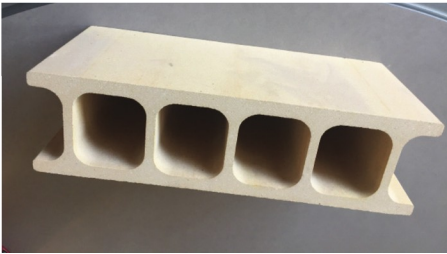

# ROLLER PASSAGES

**SITI** ROLLER PASSAGE

PITCH (mm)	WIDTH (W)	HEIGHT (H)	DEPTH (P)
67,7	403	115	200
	335		
	267	91	170
	231		
60	357,5	115	200
		91	170
	297	115	200
56,75	394	115	100
	337		

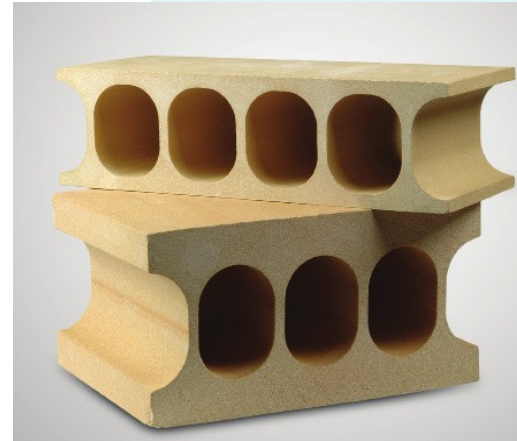

**WELKO** ROLLER PASSAGE



PITCH (mm)	WIDTH (W)	HEIGHT (H)	DEPTH (P)
72,4	357	100	170
			150
	319	100	170
			150
			170
67,7	284,5	100	170
			150
	266	100	170
			150
	231	100	170
			150
60	235	100	170
			150
	204	100	170
			150

## OTHER KILNS

Kind of Kiln	PITCH	WIDTH.(W)	HEIGHT (H)	DEPTH.(P)
Nassetti	60	238	124	180
Tecoma	60	223	115	180
	46	183	82	170
Kemac	48,8	288	82	180



# Si-SiC BARS and Si-SiC ROLLERS

Si-SiC Silicium Carbide is a material with very interesting characteristics for ceramic applications. It's a ceramic material with a very high elasticity module, exceptional hardness and a low linear expansion coefficient.

The material is produced with square, rectangular or round tubular patterns; or in plates.

20x20
30x40
40x40
40x50
40x60
50x60
60x60
60x47

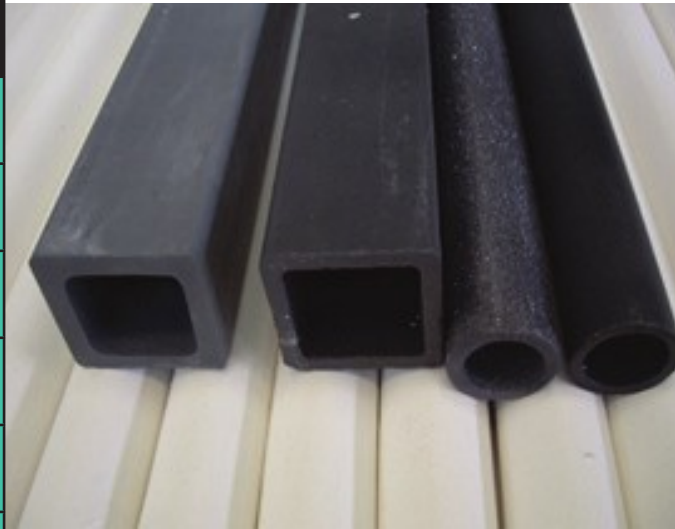

## Bottom Batts

ONE STANDARD SIZE:  
290 X 320 X 10 mm

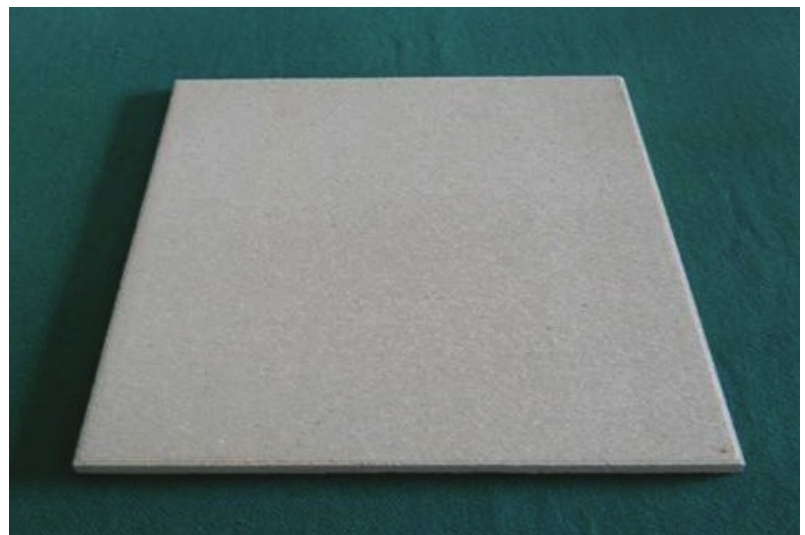

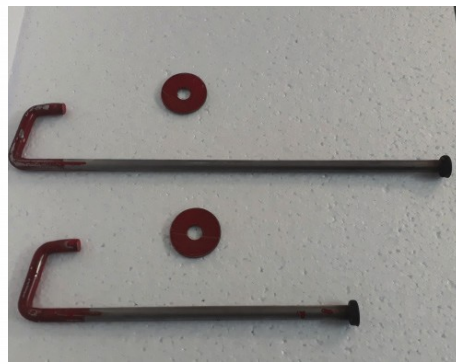
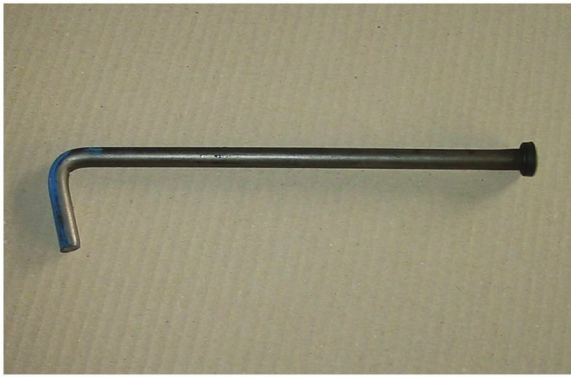

# Hook

Quality : RED / BLUE



CLASSIC SIZE L=297mm / 274 mm / 320 mm

# INTERMEDIATE BATTS

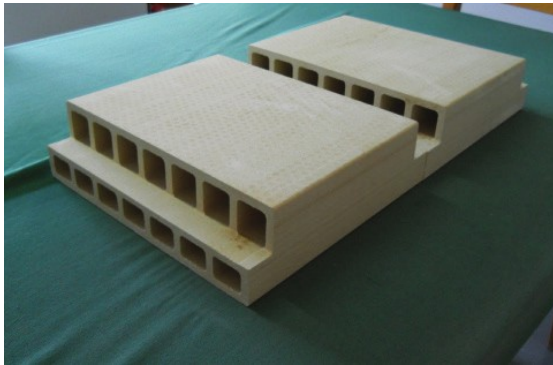

sacmi

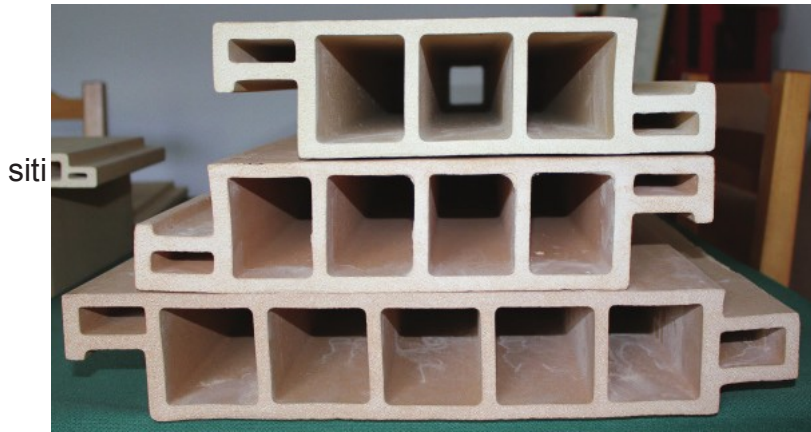
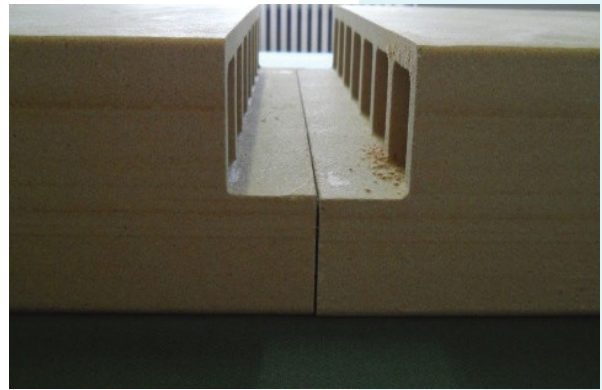

siti



# THERMOCOUPLES

S: (1500°C) 1 Platinum wire + 1 Platinum/Rhodium wire  
K: (1100°C) 1 Nickel/Chrome wire + 1 Nickel/Aluminum wire



# Ceraboard

Ceraboard is a rigid panel based on refractory fibers, characterized by regular thickness and good mechanical resistance both hot and cold



It is used as an insulating element. In particular, thanks to the high flame and erosion resistance of hot gases, it is suitable for first layer insulation (direct exposure to fire).

Some possible applications are:

- kiln coating
- insulation of kiln cars used for firing
- smoke duct insulation
- high temperature insulation

Quality	Working temperature
Ceraboard 100	1260°C
Ceraboard 115	1400°C

## AVAILABILITY:

STANDARD DIMENSIONS (mm)	Ceraboard 100		Ceraboard 115	
	cardboard	Pallet	cardboard	Pallet
1200x1000x6	20	160	-	-
1200x1000x7,5	16	120	-	-
1200x1000x10	12	90	-	-
1200x1000x13	10	72	-	-
1200x1000x15	8	60	-	-
1200x1000x20	6	48	-	-
1200x1000x25	5	36	5	36
1200x1000x40	3	24	3	24
1200x1000x50	2	18	2	18

Panels are packed in cardboards or on pallet with shrinkable and recyclable plastic film.



# INSULATING BLOCKS

Insulating blocks for kiln vault are a range of products designed for use in suspended flat roofs

Each block is composed by two JM insulating brick sections, firmly bonded with concrete and with a stainless steel support plate included .

Insulating blocks for roof are used mainly as a surface layer in kiln vault, replacing classic arched roofs

Quality	Working temp.
JM23	1260°C
JM26	1430°C
JM28	1540°C
JM30	1650°C

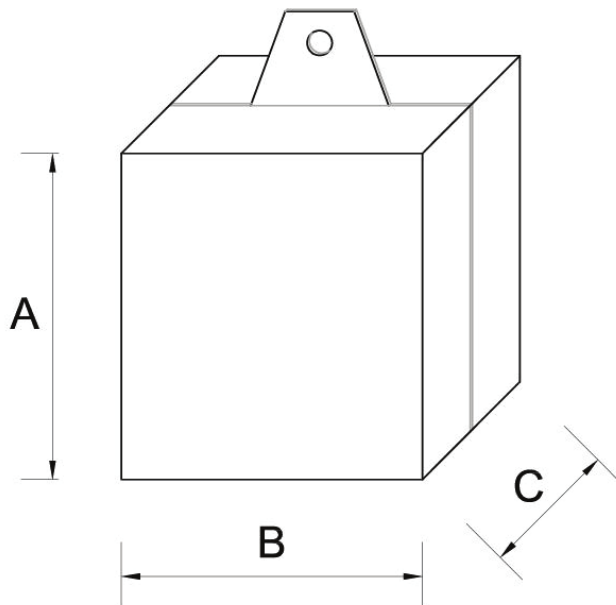
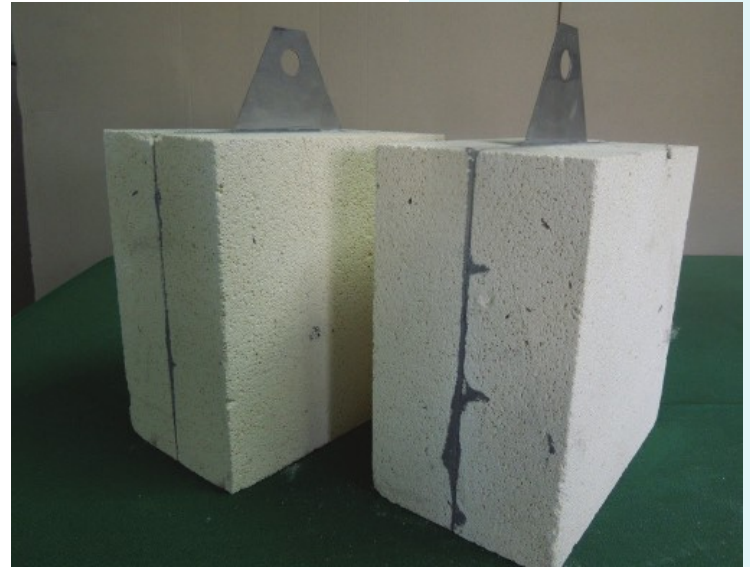

## AVAILABILITY

AxB (mm)	C (mm)
230x230	130
	154
305x230	130
	154
250x250	130
259x230	130
230x259	130

A=HEIGHT

B=WIDTH

C=DEPTH

ATTENTION: first written dimension is always HEIGHT(mm)

# INSULATING BRICKS

Insulating bricks can be used a first layer coating, therefore by direct exposure to fire, or in the second layer behind dense refractory materials.

In addition to bricks, large sizes called "SLEBI" are also available; they allow realization of special pieces, and because of big sizes it's possible to reduce number of pieces and of gluing joints in coatings

Quality	Working Temp.	Density (kg/dm <sup>3</sup> )
JM23	1260°C	0,48
JM26	1430°C	0,80
JM28	1540°C	0,89
JM30	1650°C	1,02
JM32	1760°C	1,25

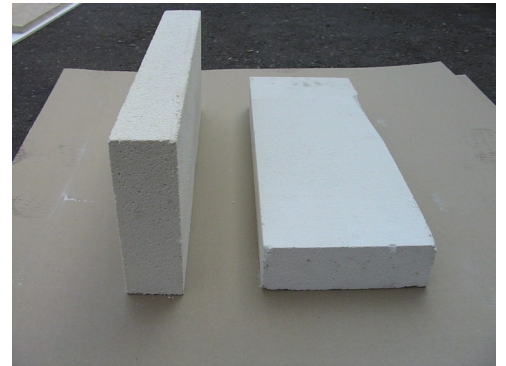

## AVAILABILITY OF INSULATING BRICKS

N. pcs/ cardboard	N. pcs/pallet			Dimensions(mm)
	JM23	JM26/28	JM30/32	
25	1200	1050	900	220X110X60
16	384	384	384	165
12	288	288	288	220
25	1200	1050	900	230X114X64
20	480	480	480	152
20	480	480	480	172
16	384	384	384	178
15	360	360	360	230
10	240	240	240	305
5	120	120	120	610
20	960	840	720	230X114X76
16	384	384	384	152
16	384	384	384	172
13	312	312	312	178
12	288	288	288	230
8	192	192	192	305
4	96	96	96	610
25	1050	900	750	250X124X64
16	384	384	384	187
12	288	288	288	250
5	120	120	120	640



# PULLING EQUIPMENT

The advancement of the tiles in the kiln takes place through ceramic rollers, which are rotated by the pulling members.

Refrattari Speciali can offer springs, bushings and pins for setting up the pulling system

## BUSHES PULLING ROLLER AND NEUTRAL



BUSHINGS FOR NASSETTI/CARFER KILN

## ROUND AND SQUARE WIRE SPRINGS

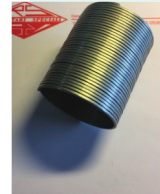
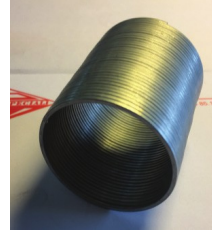

## LITTLE PULLING SPRINGS



## BUSHINGS FOR WELKO KILN



## PINS FOR ROLLER PULLING



## THIRD FIRE PINS



## SPECIAL PINS



## SITI KILN PINS 19 and 21 tooths



## SACMI KILN PINS



# VARIOUS PRODUCTS



Shaped plate for roller kiln

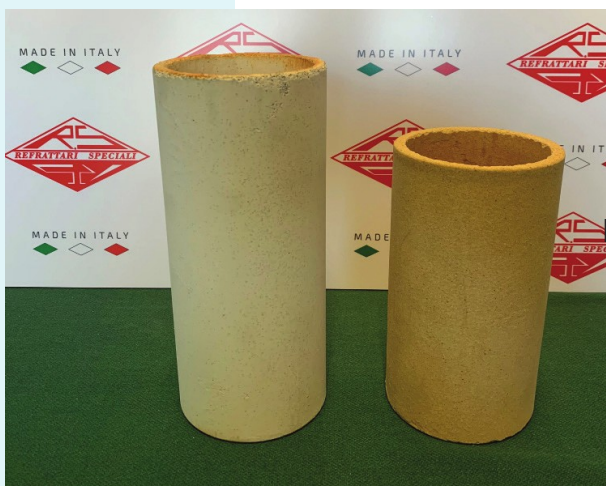

burner cover

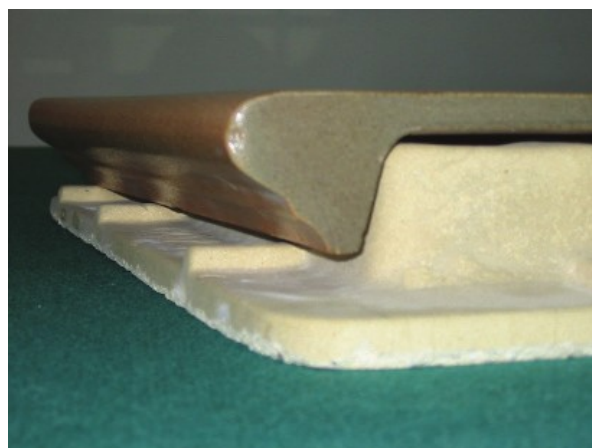

step firing support /L element

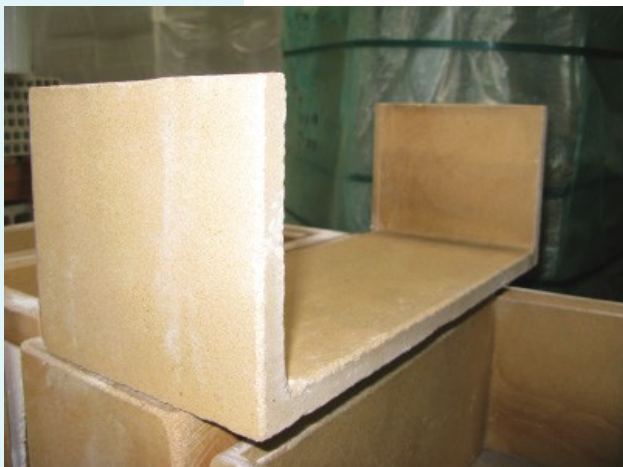

kiln inspection





# ARTISTIC SECTOR

Column h 1000 mm + base

Definitive solution for firing in artistic sector kilns, where there's the need to change the size of the product to be cooked.

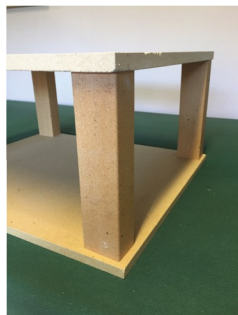

Supports/ little columns of different shapes to equip multiple shelves

## Various Products

Lego support for raised firing

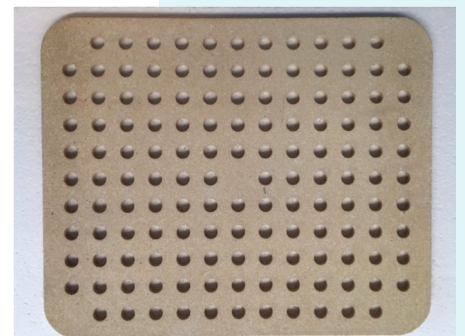
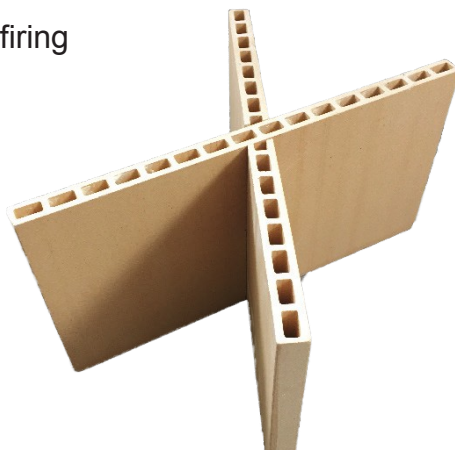

# STANDARD FIBERS

Raw and long fibers used for filling expansion joints.

These types of fibers are very resistant to attack by chemical compounds, they have good chemical stability and high resistance even for filling complex or difficult-to-access volumes, for filling repairs or as a reinforcing fiber for concrete and cement.

**AVAILABILITY:**

these fibers are packed in cardboards of 20 Kg each or in packagings of 60-80 Kg



Quality	Working temp.	
CERAFIBER	1315°C	centrifuged refractory fiber, made with electrically fused Alumina and Silica
CERACHEMFIBER	1426°C	centrifuged refractory fiber, manufactured with electrically fused Alumina, Silica and Zirconium

# ECOLOGICAL FIBERS



Ecological refractory fiber lubricated for high temperature. It consists of a set of long, non-oriented biosoluble fibers with a soft appearance; it has excellent thermal stability and retains its soft fibrous structure up to the classification temperature.

It emits neither smoke nor smell during the first heating. the material is practically unalterable by thermal shocks

AVAILABILITY: material is packed in cardboards of 20 Kg (640x595x550 mm) on pallets of 16 carboards each (1210x1310x2340 mm)

Quality	Working Temperature
SuperWool PLUS	1200°C
SuperWool HT	1300°C



# FIBER MATTRESSES



Mat for thermal insulation made with high temperature refractory ceramic fiber. They are characterized by excellent resistance to chemical attack, excellent thermal insulation and low thermal capacity. they are used for thermal insulation of kilns, flue pipes, kiln vaults, and for sealing oven doors.

AVAILABILITY: material is packed in cardboards, on pallet with shrink plastic film

Quality	Working Temp.
Cerablanket	1260°C
Cerachemblanket	1425°C

THICK-NESS	CERABLANKET			CERACHEM BLANKET			LENGTH (mm)	WIDTH (mm)
	Density (kg/m³)			Density (kg/m³)				
	96	128	160	96	128	160		
13	x	x	x	x	x	x	14640	610
19	x	x	x	x	x	x	9760	
25	x	x	x	x	x	x	7320	
50	x	x		x	x		3660	

# ECOLOGICAL FIBER MATTRES

THICK-NESS (mm)	SUPERWOOL PLUS				SUPERWOOL HT			LENGTH (mm)	WIDTH (mm)
	Density (kg/m³)				Density (kg/m³)				
	80	96	128	160	96	128	160		
13	X	X	X	X	X	X	X	14640	610
19	X	X	X	X	X	X	X	9760	
25	X	X	X	X	X	X	X	7320	
50	X	X	X		X	X	X	3660	



AVAILABILITY: material is packed in cardboards, on pallet with shrink plastic film



# OTHER

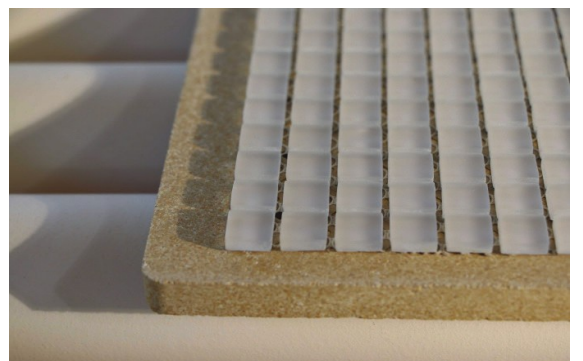
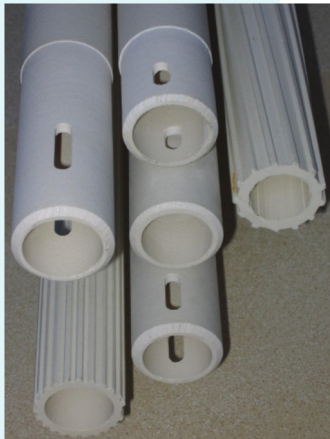
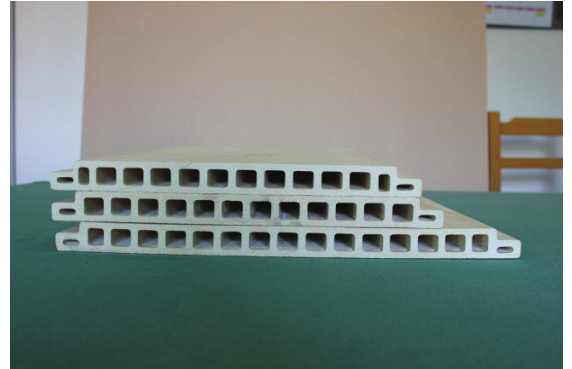
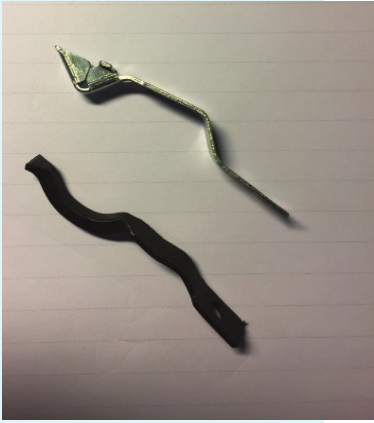

# OTHER

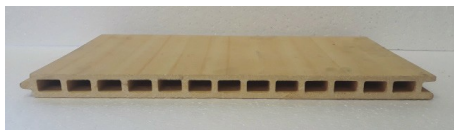
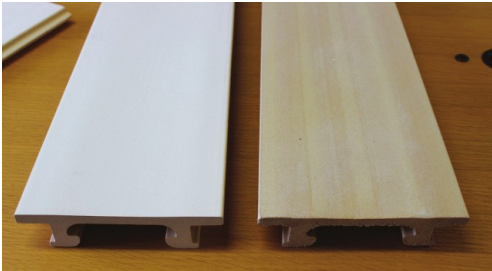

*innovative spare parts*

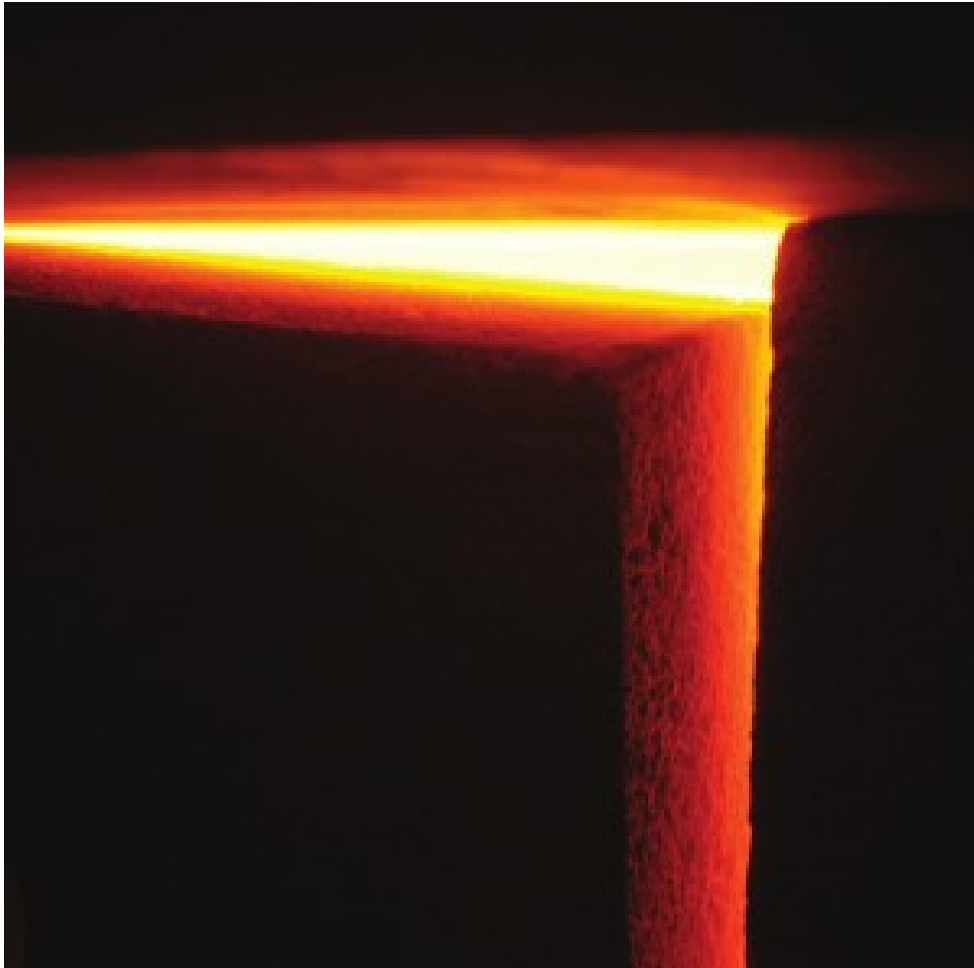

**45 years**  
with you



Refrattari speciali

Via della Repubblica, 26

42014 Castellarano

0536/851785 - [refrattari-speciali.it](http://refrattari-speciali.it) / [info@refrattari-speciali.it](mailto:info@refrattari-speciali.it)

Rev.1.10 en